

6GSUBST20 HIGH VOLUME TRASH



Global Pump® portable electric submersible pumps are ideal for stationary wet pit (P type) and mobile wet pit (S type) installation.

The Model 6GSUBST20 pump with 6" (150 mm) flange or hose and a 20 hp (25 kW) motor is ideal for medium volume, medium head applications.

STATIONARY (SEMI PERMANENT) WET PIT INSTALLATION

A	B	C	D	E	F	G	H	I	J	K	L	M	N	O	P	R	S
1200	85	130	765	390	215	139	510	435	250	950	125	150	850	425	950	200	23

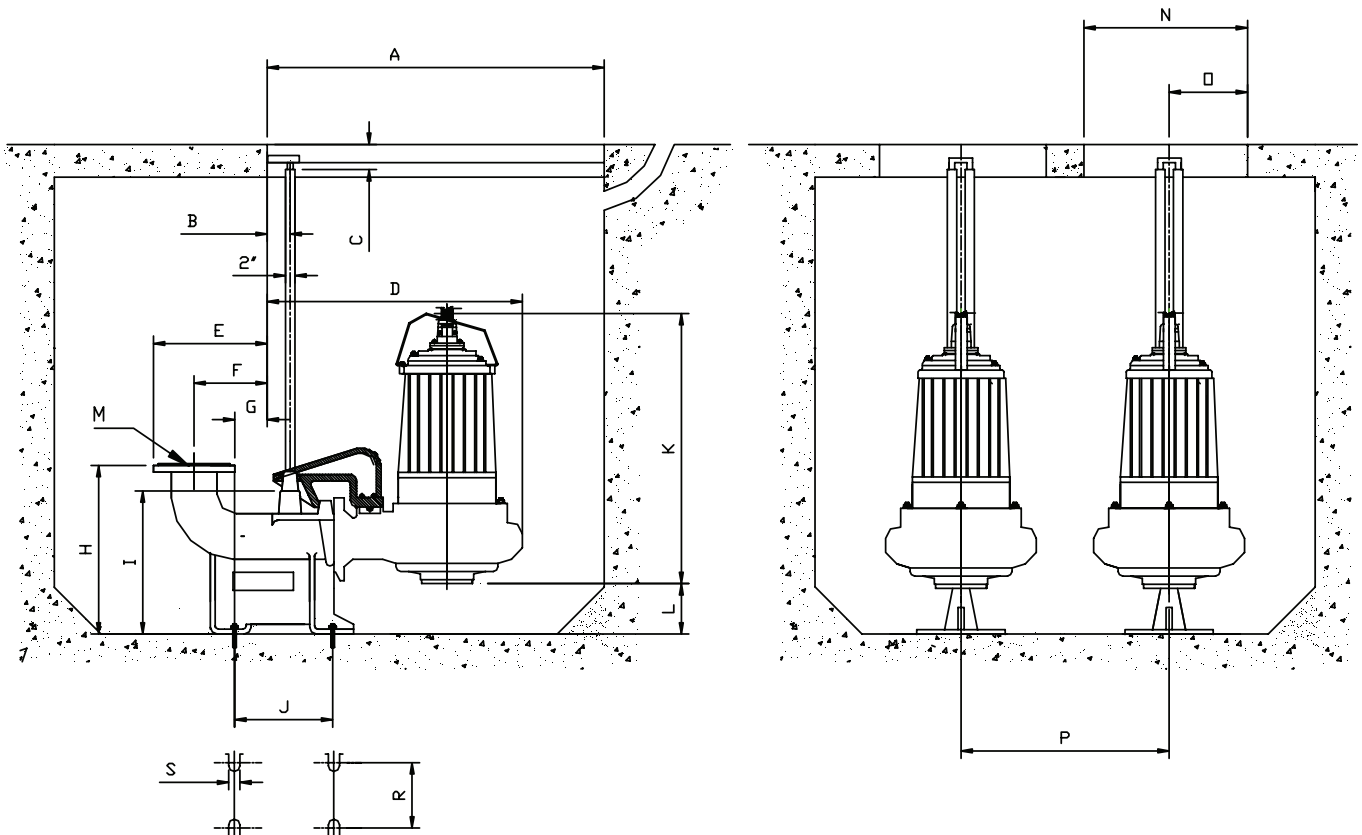

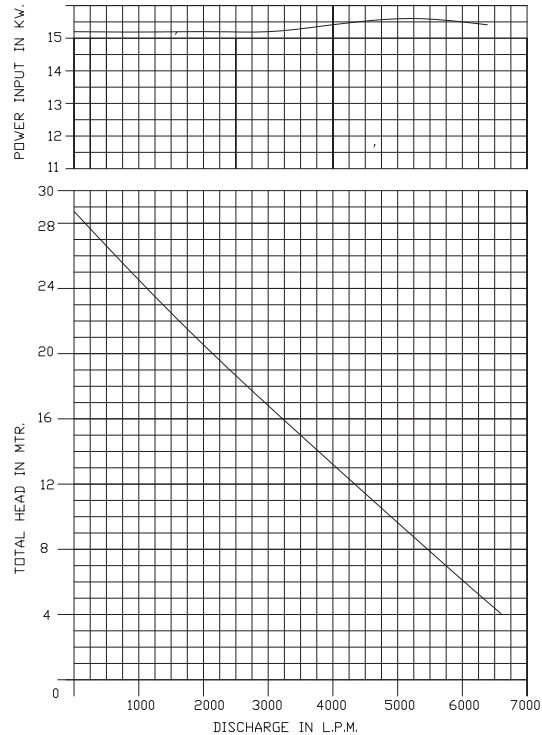
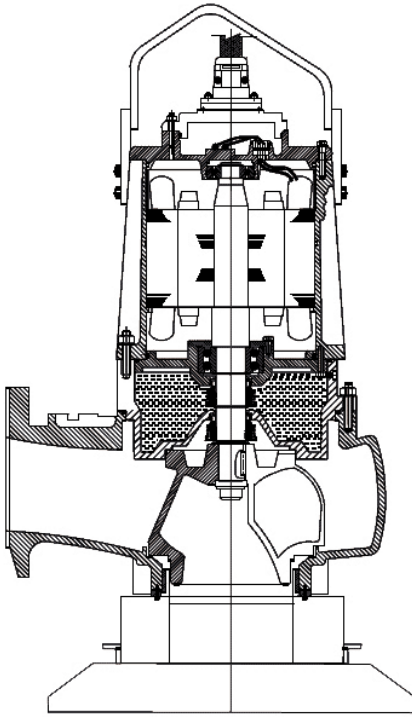

SPECIFICATIONS

Size	6" (150 mm)
Power	20 hp (25 kW)
Max Flow	1717 gpm (390 m ³ /h)
Max Head	95' (29 m)
Motor	4-pole induction continuous rated motor with squirrel cage rotor. Bi-metallic switches (thermal) embedded in stator winding to protect against overheating. Stator insulation class 'H' (180°C)
Speed (motor)	1,750 RPM @ 60 Hz, 1,450 RPM @ 50Hz
Power Rating (motor)	20 hp @ 60 Hz, 7.5 kW @ 50 Hz Full Load
Current FLA (motor)	28 Amps @ 460v, 16 Amps @ 400v
Solids Handling	4" (100 mm)
Max. temperature of the pump liquid (motor)	104°F/40°C
Max. start/stop per hour (motor)	15
Power Supply	3 phase, 50/60 Hz, AC Supply. Available in any voltage frequency combination (208/220/230/380/415/460/575/1,000V)
Power Cable	50' (15 m) length standard
pH Range	6 - 11
Submergence	Submergence below liquid surface max. 33' (10 m)
Weight (approx. w/o cable)	P Type - 528 lbs. (240 Kg) S Type - 440 lbs. (200 Kg)

PUMP MATERIAL

Outer Casing	Cast Iron ASTM A48 Class 30 (FG220)
Impeller	Cast Iron ASTM A48 Class 30 (FG220)
O-rings	Nitrile rubber
Hardware	304 Stainless steel
Shaft	431 Stainless steel
Mechanical Seals	Tandem tungsten carbide/tungsten carbide upper and lower
Impeller	Nitride-hardened 410SS to 56HRC (Standard)
Ball Bearings	Rotor shaft carried in two ball bearings. Double row contact lower bearing capable of carrying high thrust and radial loads. Oversized deep groove single row upper bearing. Bearings enclosed with high temperature grease containing special anti-corrosion additive
Power Cable	Waterproof/oil proof, rubber-insulated, neoprene-sheathed copper conductor flexible cable. Type SOOW in North America, EPR in the Middle East and HO7RN in the EU. 6 Core or Control cable with thermal overloads optional
Surface Treatment	Primer with epoxy surface treatment coated with black chloric paint

 **GLOBAL PUMP**[®]

GLOBAL PUMP

10162 East Coldwater Road, Davison, MI 48423

Tel: 810.653.4828 Fax: 810.658.0632

1.866.360.PUMP

www.globalpump.com