

## 6GSCWP GLOBAL STANDARD CENTRIFUGAL WELLPOINT



Global Pump® Standard Centrifugal Wellpoint pumps are specifically designed to effectively handle the arduous requirements of wellpoint and underdrain dewatering systems where intermittent water flow and large amounts of air are encountered.

Global Pump Standard Centrifugal Wellpoint pumps provide a compact, dependable, highly efficient solution in a completely automatic priming pump with built in air separation.

The model 6GSCWP is capable of achieving maximum flows of 1,350 gpm (307 m<sup>3</sup>/h) and maximum total head of 108' (33 m), with solids handling up to 0.75" (19 mm) in diameter. The standard 6GSCWP is powered by a water-cooled, 4-cylinder diesel engine. Alternative drives are available, including other diesel engines or electric motor options.

FEATURES	OPTIONS
Global Pump's rugged, heavy duty pumps are engineered specifically for portable application	Fuel tanks for extended run times and/or remote location as required
Belt-driven, vacuum pump provides high air handling and a fully automatic priming system	Highway trailer with integral fuel cell/chassis, lights, fenders, tie downs, lifting bail, front and rear jacks
Fully guarded coupling, pulley and belting	Trailer brakes can be offered as required
High efficiency air separation tank separates air and water before entering the pump	Sound attenuated enclosure options
Condensation chamber with drain contains any condensation or water vapor from the air	Hose racks, accessory containers and other custom features available as required
Oil recovery system separates and removes oil and other particulates from the discharge air	Wide range of suction and discharge fittings available including Global's own "QD" Quick Disconnect fittings and accessories
Non-return valve uses only a single moving part to allow full flow with minimal restriction	
Pump casings are hydrostatically tested to 50 psig (345 kPa) above the peak casing design pressure	
Standard engine control panel provides preset emergency shutdown protection and allows the addition of automatic level control	
Standard skid-mounted format with integral fuel tank, tie downs, lifting bail and fork pockets	

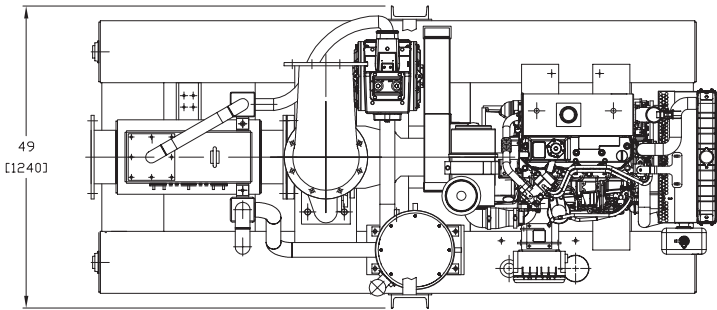
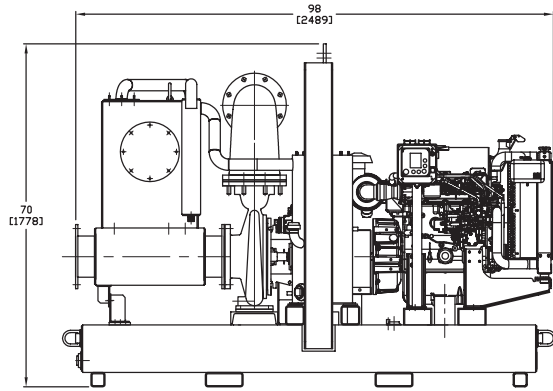

**SPECIFICATIONS**

Connections	6" (150 mm) ANSI Flanges
Maximum Pump Speed	1,800 rpm
Maximum Flow	1,350 gpm (307 m3/h)
Maximum Head	108' (33 m)
Maximum Static Priming Lift	28' (8.5 m)
Water Temperature Limit	60° F (70° C)
Solids Handling Capability	0.75" (15 mm)
Maximum Casing Pressure	150 psig (1034 kPa)
Standard Compact Fuel Tank	70 gallons (265 liters)
Dry Weight	3,200 lbs

**PUMP MATERIAL**

Casing	Cast Iron
Impeller	Cast Iron
Bearing Housing	Cast Iron
Bearing Lubrication	Grease
Shaft	Steel
Shaft Sleeve	Stainless Steel
Seal	Carbon on Ceramic
Chassis/Fuel Cell	Steel
Non-Return Valve	Nitrile fitted Cast Iron
Air Separation Tank	Steel
Oil Recovery Tank	Steel

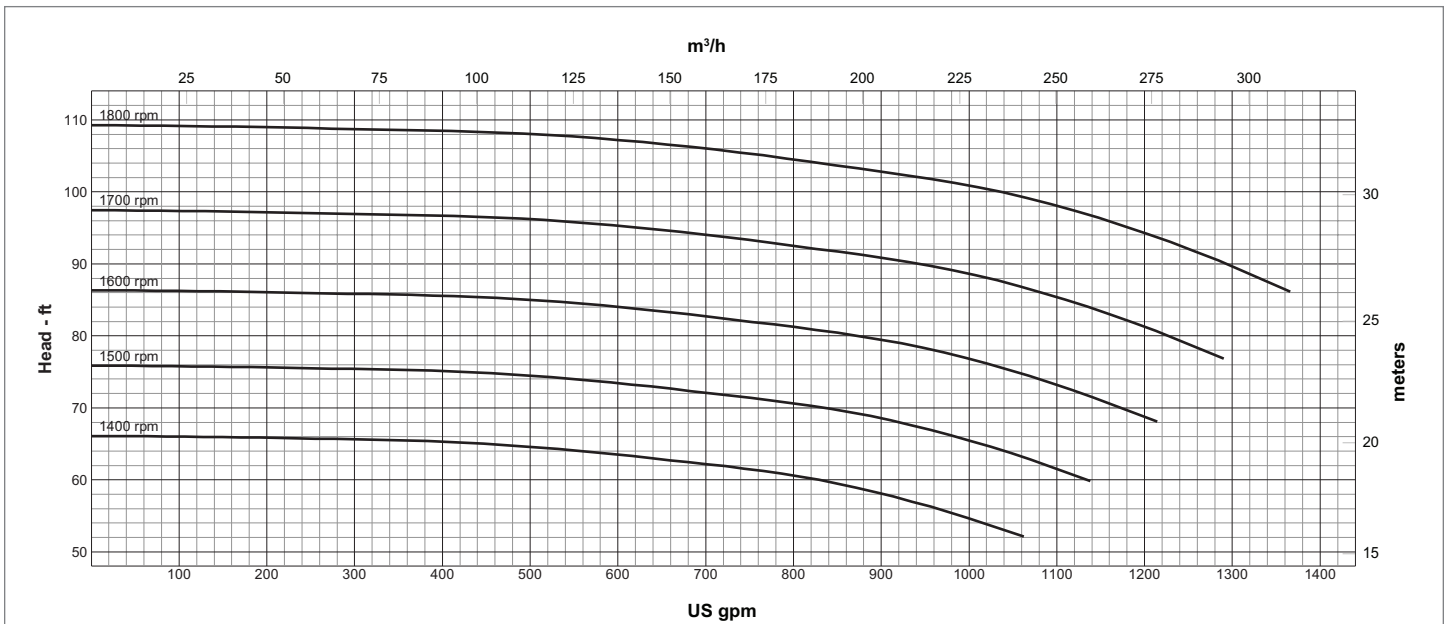

**GLOBAL PUMP**  
 10162 East Coldwater Road, Davison, MI 48423  
 Tel: 810.653.4828 Fax: 810.658.0632  
**1.866.360.PUMP** [www.globalpump.com](http://www.globalpump.com)