

4GHT  
GLOBAL HIGH  
PERFORMANCE TRASH



Global Pump<sup>®</sup> High Performance Trash pumps are specifically designed to effectively handle a wide-range of liquids from water to sewage and sludge that can contain solids and other material.

Global Pump High Performance Trash pumps provide a dependable, highly efficient solution. The model 4GHT is capable of achieving maximum flows of 1,600 gpm (341 m<sup>3</sup>/h) and maximum total head of 174' (53.3 m) while handling solids up to 3" (76.2 mm) in diameter.

The standard 4GHT is powered by a water-cooled, 4-cylinder diesel engine. Alternative drives are available, including other diesel engines or electric motor options.

**FEATURES**

Global Pump's rugged, heavy duty pumps are engineered specifically for portable application

Non-return valve uses only a single moving part to allow full flow with minimal restriction

Standard engine control panel provides preset emergency shutdown protection and allows the addition of automatic level control

Fully guarded coupling

Pump casings are hydrostatically tested to 50 psig (345 kPa) above the peak casing design pressure

Highway trailer with integral fuel cell/chassis, lights, fenders, tie downs, lifting bail, front and rear jacks. Trailer brakes can be offered as required

**OPTIONS**

Available with a variety of priming systems, including Global's Auto Prime<sup>®</sup> automatic priming system (compressor-fed venturi priming) or a diaphragm priming system

Mechanical seal with glycol (biodegradable optional) quench allows the pump to start and run dry

Global Pump's Environmental Box separates and silences air exhaust and returns liquid to the pump suction.

Fuel cubes for extended run times and/or remote location as required

Sound attenuated enclosure options

Skid-mounted formats with tie downs, lifting bail, and fork pockets

Hose racks, accessory containers and other custom features available as required

Wide range of suction and discharge fittings including Global Pump's own "QD" Quick Disconnect fittings and accessories

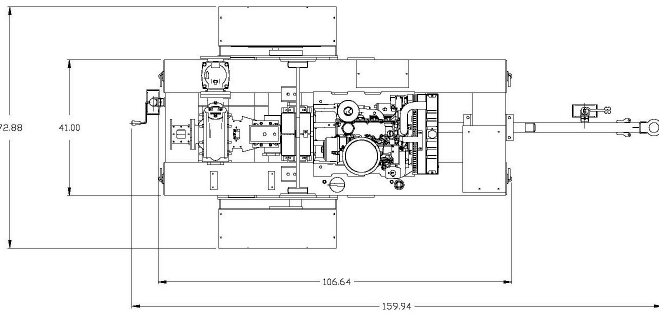
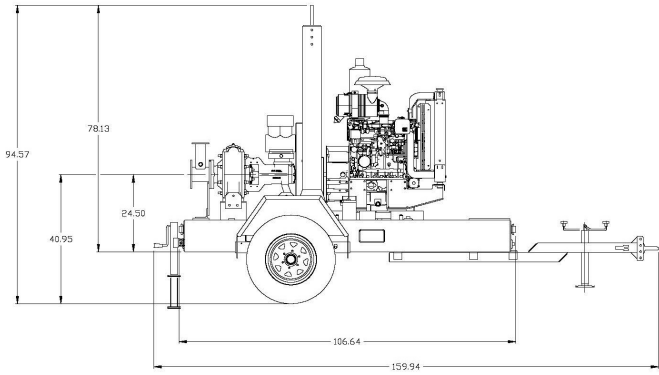

**SPECIFICATIONS**

|                            |                                   |
|----------------------------|-----------------------------------|
| Connections                | 4" (100 mm) ANSI Flanges          |
| Max Pump Speed             | 2,200 rpm                         |
| Max Flow                   | 1,600 gpm (341 m <sup>3</sup> /h) |
| Max Head                   | 174' (53 m)                       |
| Max Static Priming Lift    | 28' (8.5 m)                       |
| Temperature Limit          | 160° F (70° C)                    |
| Solids Handling Capability | 3" (76.2 mm)                      |
| Max Casing Pressure        | 125 psig (862 kPa)                |
| Fuel Cell                  | 85 gallons (320 liters)           |
| Dry Weight                 | 3,650 lbs                         |

**PUMP MATERIAL**

|                     |                                    |
|---------------------|------------------------------------|
| Casing              | Cast Iron (CD4MCu is an option)    |
| Impeller            | Cast Iron (CD4MCu is an option)    |
| Bearing Housing     | Cast Iron                          |
| Bearing Lubrication | Grease                             |
| Shaft               | Stainless Steel                    |
| Seal                | Silicon Carbide on Silicon Carbide |
| Chassis/Fuel Cell   | Steel                              |
| Non-Return Valve    | Nitrile Fitted Cast Iron           |

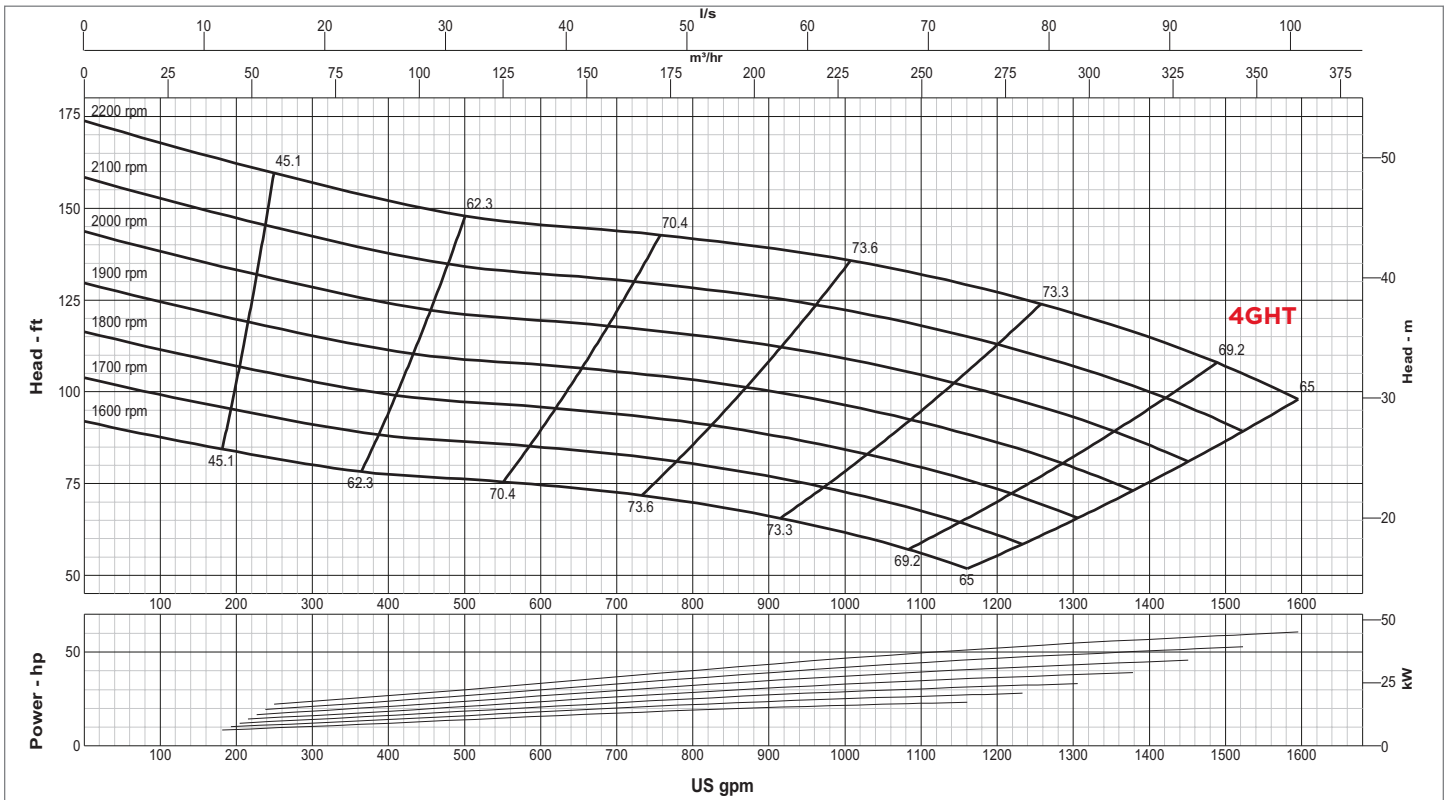

**GLOBAL PUMP**  
 10162 East Coldwater Road, Davison, MI 48423  
 Tel: 810.653.4828 Fax: 810.658.0632  
**1.866.360.PUMP** [www.globalpump.com](http://www.globalpump.com)