

12GSH GLOBAL STANDARD HIGH HEAD

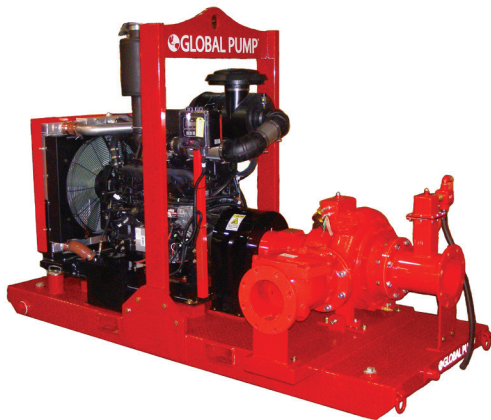

Global Pump® Standard High Head pumps are specifically designed to effectively handle a wide-range of liquids in applications such as liquid transfer, wash down, fire protection, fracking and jetting where high heads and pressure are required.

Global Pump Standard High Head pumps provide a dependable, highly efficient solution. The model 12GSH is capable of achieving maximum flows of 6,750 gpm (1,533 m³/h) and maximum total head of 340' (104 m), with solids handling up to 1.5" (38.1 mm) in diameter.

The standard 12GSH is powered by a water-cooled, 6-cylinder diesel engine. Alternative drives are available, including other diesel engines or electric motor options.

FEATURES

Global Pump's rugged, heavy duty pumps are engineered specifically for portable application

Non-return valve uses only a single moving part to allow full flow with minimal restriction

Standard engine control panel provides preset emergency shutdown protection and allows the addition of automatic level control

Fully guarded coupling

Pump casings are hydrostatically tested to 50 psig (345 kPa) above the peak casing design pressure

Skid-mounted formats with tie downs, lifting bail, and fork pockets

OPTIONS

Available with a variety of priming systems, including Global's Auto Prime® automatic priming system (compressor-fed venturi priming) or a diaphragm priming system

Mechanical seal with glycol (biodegradable optional) quench allows the pump to start and run dry

Global Pump's Environmental Box separates and silences air exhaust and returns liquid to the pump suction.

Fuel cubes for extended run times and/or remote location as required

Sound attenuated enclosure options

Hose racks, accessory containers and other custom features available as required

Wide range of suction and discharge fittings including Global Pump's own "QD" Quick Disconnect fittings and accessories

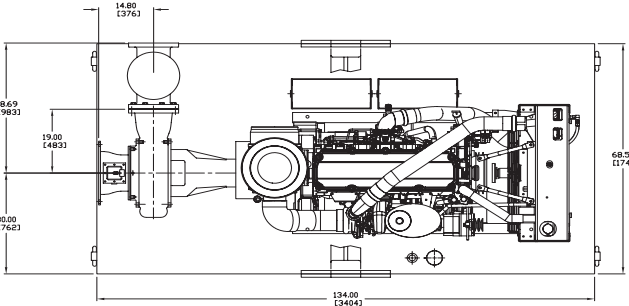
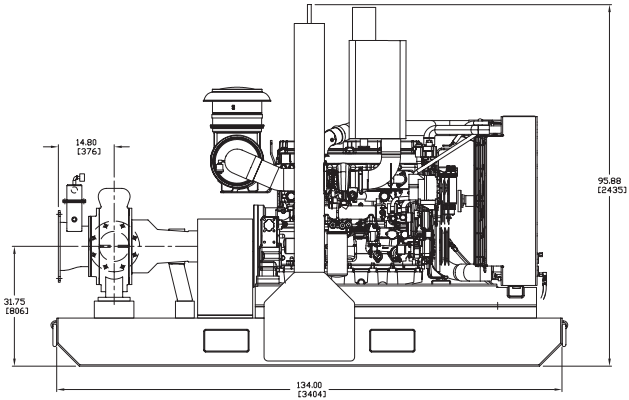

SPECIFICATIONS

Connections	12" x 8" (300 mm x 200 mm) ANSI Flanges
Max Pump Speed	2,000 rpm
Max Flow	6,750 gpm (1,533 m ³ /h)
Max Head	340' (104 m)
Max Static Priming Lift	28' (8.5 m)
Temperature Limit	160° F (70° C)
Solids Handling Capability	1.5" (38.1 mm)
Max Casing Pressure	200 psig (1379 kPa)
Fuel Cell	325 gallons (1230 liters)
Dry Weight	13,500 lbs

PUMP MATERIAL

Casing	Cast Steel (CD4MCu is an option)
Impeller	CD4MCu
Bearing Housing	Cast Iron
Bearing Lubrication	Grease
Shaft	Stainless Steel
Seal	Silicon Carbide on Silicon Carbide
Chassis/Fuel Cell	Steel
Non-Return Valve	Nitrile Fitted Cast Iron

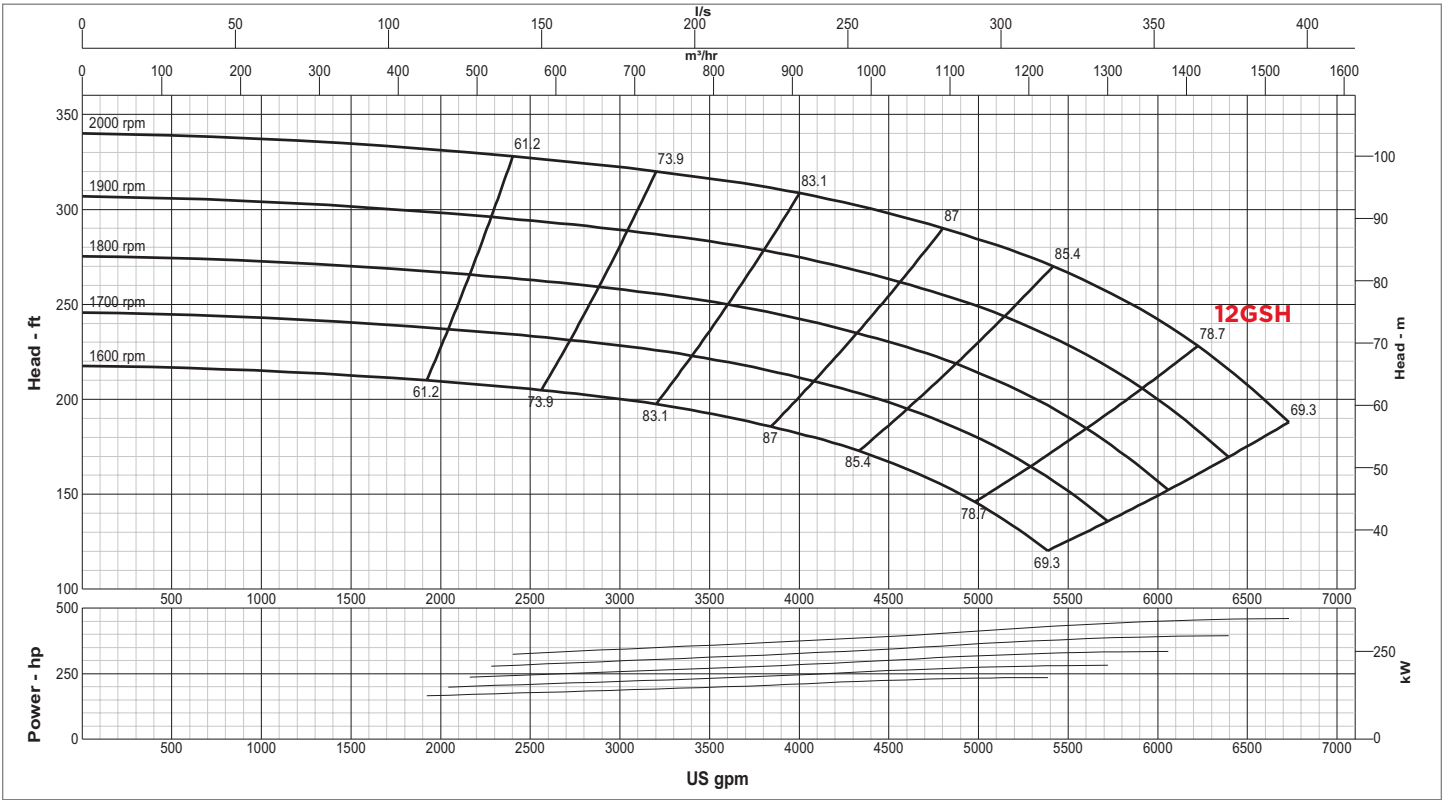

GLOBAL PUMP
 10162 East Coldwater Road, Davison, MI 48423
 Tel: 810.653.4828 Fax: 810.658.0632
1.866.360.PUMP www.globalpump.com